

Serie Heavy

SR307F

Nylon Cable Chain

with un-screwable split cross pieces with holes

Strong double share Sideband & Frame construction with large anti-friction triple-pin. Un-screwable nylon split cross pieces with different hole combinations. As standard the chain comes with frames every second link, on request with frames every link.

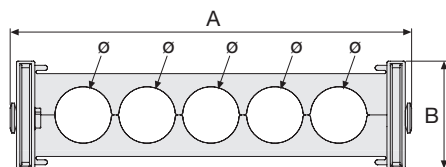

Pin

Part.no PG307

Technical characteristics when self-supported

Speed	8 m/s
Acceleration	40 m/s ²

For higher requirements please consult our technical dept.

A	B	N.	Ø	R	Weight/m	Chain
mm	mm	holes	mm	mm	kg	Part Number
126	64	2	34	075-090-120-140-200-250	2,20	SR307001 □*
214	64	6	25	075-090-120-140-200-250	2,50	SR307002 □*
242	64	5	34	075-090-120-140-200-250	2,70	SR307003 □*
279	64	6	34	075-090-120-140-200-250	2,95	SR307004 □*
113	64	3	23	075-090-120-140-200-250	2,10	SR307005 □*

*Complete the code by inserting the value of the radius (R): Ex. SR307002 [1]

Where: 0=090; 1=120; 2=140; 3=200; 4=250; 7=075

Chain equipped with nylon frame every pitch: complete the code by inserting the letter D.

Ex. SR3070021 [D]

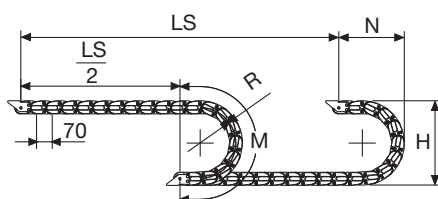

R	H	N	M
mm	mm	mm	mm
075	214	180	375
090	244	195	425
120	304	225	520
140	344	245	580
200	464	305	770
250	564	355	925

Length of chain (L)

Half travel distance ($\frac{LS}{2}$) plus length of curve (M)

$$L = \frac{LS}{2} + M$$



Self-Supporting Capacity Diagram

The maximum length of the self-supporting capacity ($\frac{LS}{2}$) in relationship to the weight of the cables and hoses contained per linear metre.

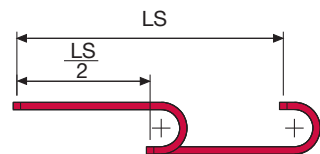
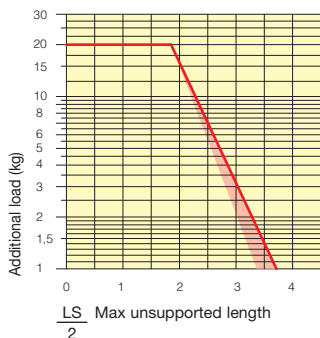

The red marking in the diagram area considers the difference of weight between various widths of chains assembled with nylon cross pieces every second pitch.

For applications with $\frac{LS}{2}$ and weights not included in the area of the diagram showing self-supporting capacity, verify the possible use of support rollers (see page 30).

End Brackets

The end brackets set allows the two ends of the chain to be attached to the equipment.

Nylon Type

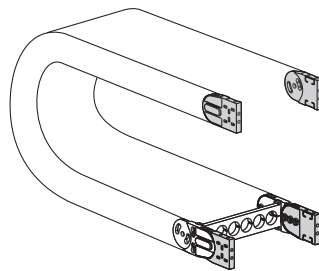

Fig. A
The chain can be fixed frontally, inner or outer radius. (Fig A)

Bright Zinc Plated Steel Type*

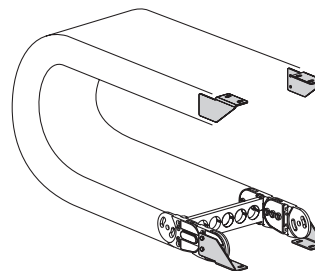
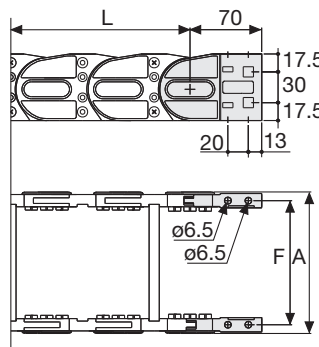
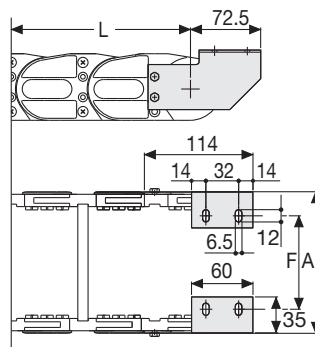

Fig. B
Chain fixed outside the radius. (Fig B)
See end brackets mounting variations page 31.



Chain Type	F mm
SR307001	107
SR307002	195
SR307003	223
SR307004	260
SR307005	94



Chain Type	F mm
SR307001	77
SR307002	165
SR307003	193
SR307004	230
SR307005	64

Nylon Type Part Numbers

Complete Set Assembled	
Chain Type	End Brackets Set
SR30700...	AN307KM

Complete Set Unassembled	
Chain Type	End Brackets Set
SR30700...	AN307K

Bright Zinc Plated Steel Type Part Numbers

Complete Set Assembled	
Chain Type	End Brackets Set
SR30700...	A307KM □**

Complete Set Unassembled	
Chain Type	End Brackets Set
SR30700...	A307K □**

*Available on request in stainless steel
** 1=Pos.1; 2=Pos.2; 3=Pos.3
See end brackets mounting variations page 31.

Serie Heavy

SR307F

Nylon Cable Chain with un-screwable nylon split cross pieces with holes

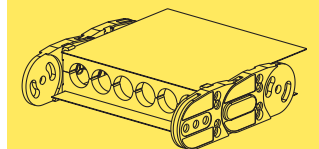

Steel laminar cover.

Special tool to remove the connecting pivots:
Part Number PZ036.

For further information please consult Brevetti Stendalto's Technical Office