

Serie Heavy

SR308F

Nylon Cable Chain

with un-screwable split cross pieces with holes

Strong double share Sideband & Frame construction with large anti-friction triple-pin. Un-screwable nylon split cross pieces with different hole combinations. As standard the chain comes with frames every second link, on request with frames every link.

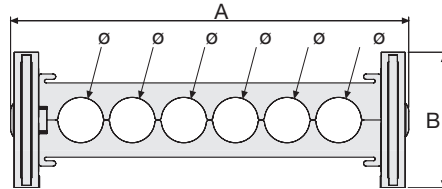

Pin
Part.no PG308

Technical characteristics when self-supported

Speed	8 m/s
Acceleration	40 m/s ²

For higher requirements please consult our technical dept.

A	B	N.	Ø	R	Weight/m	Chain
mm	mm	holes	mm	mm	kg	Part Number
132	75	2	34	150-180-200-230-280-400	3,05	SR308001 □*
220	75	6	25	150-180-200-230-280-400	3,45	SR308002 □*
248	75	5	34	150-180-200-230-280-400	3,60	SR308003 □*
285	75	6	34	150-180-200-230-280-400	3,80	SR308004 □*
132	75	2+1	28-23	150-180-200-230-280-400	3,05	SR308005 □*

*Complete the code by inserting the value of the radius (R): Ex. SR308003 □

Where: 1=150; 2=180; 3=200; 4=230; 5=280; 6=400

Chain equipped with aluminium rods every pitch: complete the code by inserting the letter D.

Ex. SR3080031 □

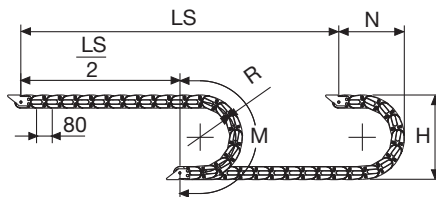

R	H	N	M
mm	mm	mm	mm
150	375	270	635
180	435	300	725
200	475	320	790
230	535	350	885
280	635	400	1040
400	875	520	1420

Length of chain (L)

Half travel distance ($\frac{LS}{2}$) plus length of curve (M)

$$L = \frac{LS}{2} + M$$



Self-Supporting Capacity Diagram

The maximum length of the self-supporting capacity ($\frac{LS}{2}$) in relationship to the weight of the cables and hoses contained per linear metre.

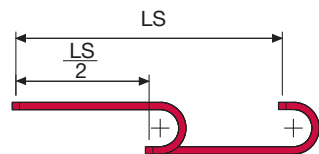
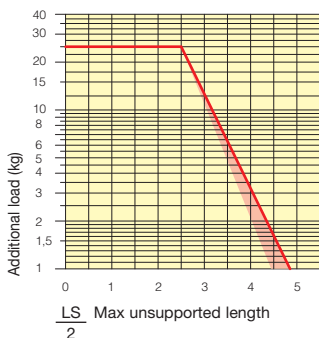

The red marking in the diagram area considers the difference of weight between various widths of chains assembled with nylon cross pieces every second pitch.

For applications with $\frac{LS}{2}$ and weights not included in the area of the diagram showing self-supporting capacity, verify the possible use of support rollers (see page 30).

End Brackets

The end brackets set allows the two ends of the chain to be attached to the equipment.

Nylon Type

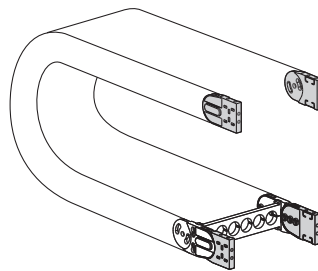

Fig. A
The chain can be fixed frontally, inner or outer radius. (Fig A)

Bright Zinc Plated Steel Type*

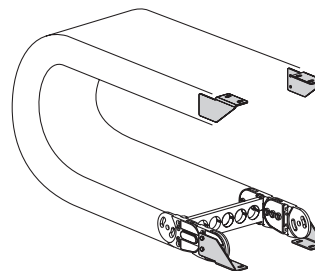
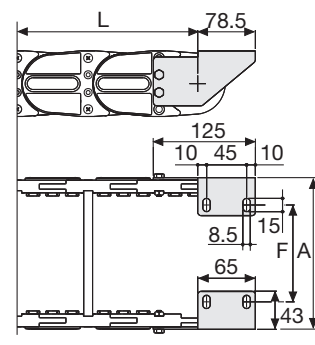
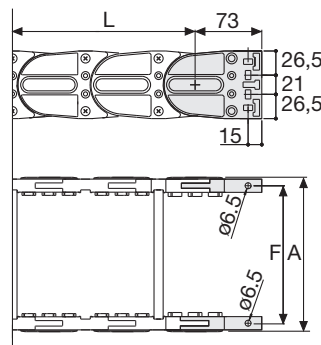

Fig. B
Chain fixed outside the radius. (Fig B)
See end brackets mounting variations page 31.



Chain Type	F mm
SR308001	111
SR308002	199
SR308003	227
SR308004	264
SR308005	111

Chain Type	F mm
SR308001	69
SR308002	157
SR308003	185
SR308004	222
SR308005	69

Nylon Type Part Numbers

Complete Set Assembled	
Chain	End Brackets
Type	Set
SR30800...	AN308KM

Complete Set Unassembled	
Chain	End Brackets
Type	Set
SR30800...	AN308K

Bright Zinc Plated Steel Type Part Numbers

Complete Set Assembled	
Chain	End Brackets
Type	Set
SR30800...	A308KM □**

Complete Set Unassembled	
Chain	End Brackets
Type	Set
SR30800...	A308K □**

*Available on request in stainless steel
** 1=Pos.1; 2=Pos.2; 3=Pos.3
See end brackets mounting variations page 31.

Serie Heavy

SR308F

Nylon Cable Chain with un-screwable nylon split cross pieces with holes

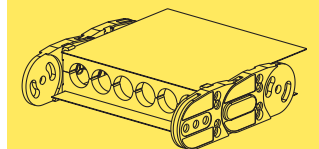

Steel laminar cover.

Special tool to remove the connecting pivots:
Part Number PZ038.

For further information please consult Brevetti Stendalto's Technical Office