

Serie Heavy

SR308SI/SR308SE

Nylon Cable Chain with openable frames

Inner height (D) 57 mm

Strong double share Sideband & Frame construction with large anti-friction triple-pin. Frames openable from inner radius (..SI) and outer radius (..SE). As standard the chain comes with frames every second link, on request with frames every link. Vertical and horizontal modular separator system is available.

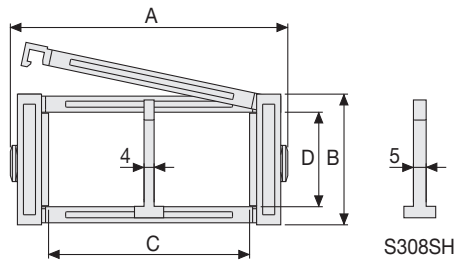

Separator

- Unassembled	Part.no S308C
- Assembled	Part.no S308CMC

Fastening separator

- Unassembled	Part.no S308SH
- Assembled	Part.no S308SHMC

Pin

Part.no PG308

Technical characteristics when self-supported

Speed	8 m/s
Acceleration	40 m/s ²

For higher requirements please consult our technical dept.

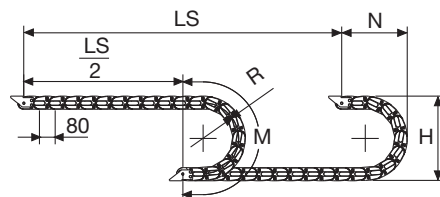

Length of chain (L)
Half travel distance ($\frac{LS}{2}$)
plus length of curve (M)

$$L = \frac{LS}{2} + M$$

R	H	N	M
mm	mm	mm	mm
150	375	270	635
180	435	300	725
200	475	320	790
230	535	350	885
280	635	400	1040
400	875	520	1420

A	B	C	D	R	Weight/m	Chain
mm	mm	mm	mm	mm	kg	Part Number
82	75	38	57	150-180-200-230-280-400	2,46	SR308SI(SE)038□□□*
93	75	49	57	150-180-200-230-280-400	2,46	SR308SI(SE)049□□□*
107	75	63	57	150-180-200-230-280-400	2,51	SR308SI(SE)063□□□*
113	75	69	57	150-180-200-230-280-400	2,53	SR308SI(SE)069□□□*
127	75	83	57	150-180-200-230-280-400	2,56	SR308SI(SE)083□□□*
132	75	88	57	150-180-200-230-280-400	2,56	SR308SI(SE)088□□□*
139	75	95	57	150-180-200-230-280-400	2,58	SR308SI(SE)095□□□*
149	75	105	57	150-180-200-230-280-400	2,59	SR308SI(SE)105□□□*
157	75	113	57	150-180-200-230-280-400	2,62	SR308SI(SE)113□□□*
168	75	124	57	150-180-200-230-280-400	2,65	SR308SI(SE)124□□□*
182	75	138	57	150-180-200-230-280-400	2,67	SR308SI(SE)138□□□*
207	75	163	57	150-180-200-230-280-400	2,73	SR308SI(SE)163□□□*
232	75	188	57	150-180-200-230-280-400	2,79	SR308SI(SE)188□□□*
243	75	199	57	150-180-200-230-280-400	2,81	SR308SI(SE)199□□□*
257	75	213	57	150-180-200-230-280-400	2,84	SR308SI(SE)213□□□*
284	75	240	57	150-180-200-230-280-400	2,90	SR308SI(SE)240□□□*
293	75	249	57	150-180-200-230-280-400	2,92	SR308SI(SE)249□□□*
344	75	300	57	150-180-200-230-280-400	3,02	SR308SI(SE)300□□□*
366	75	322	57	150-180-200-230-280-400	3,07	SR308SI(SE)322□□□*
394	75	350	57	150-180-200-230-280-400	3,13	SR308SI(SE)350□□□*

*Complete the code by inserting the value of the radius (R): Ex. SR308SI(SE)105 □ □ □ □
Chain equipped with nylon frame every pitch: complete the code by inserting the letter D.
Ex. SR308SI(SE)105150 D



Self-Supporting Capacity Diagram

The maximum length of the self-supporting capacity ($\frac{LS}{2}$) in relationship to the weight of the cables and hoses contained per linear metre.

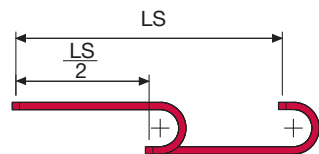
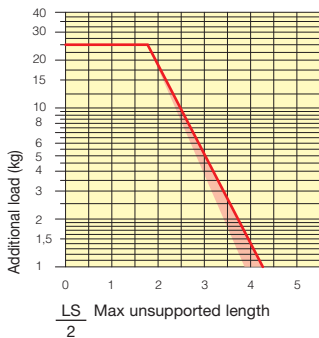

The red marking in the diagram area considers the difference of weight between various widths of chains assembled with nylon frames every second pitch.

For applications with $\frac{LS}{2}$ and weights not included in the area of the diagram showing self-supporting capacity, verify the possible use of support rollers (see page 30).

End Brackets

The end brackets set allows the two ends of the chain to be attached to the equipment.

Nylon Type

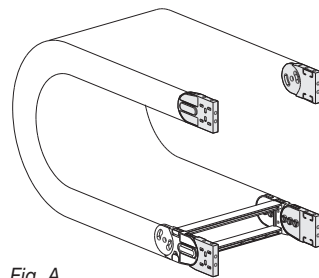
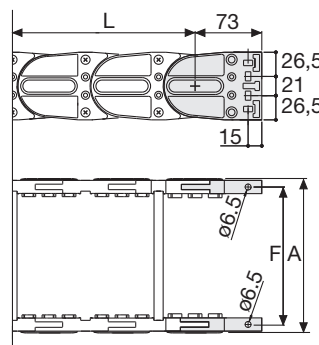

Fig. A
The chain can be fixed frontally, inner or outer radius. (Fig A)



Chain Type	F mm
SR308SI(SE)038	62
SR308SI(SE)049	73
SR308SI(SE)063	87
SR308SI(SE)069	93
SR308SI(SE)083	107
SR308SI(SE)088	112
SR308SI(SE)095	119
SR308SI(SE)105	129
SR308SI(SE)113	137
SR308SI(SE)124	148
SR308SI(SE)138	162
SR308SI(SE)163	187
SR308SI(SE)188	212
SR308SI(SE)199	223
SR308SI(SE)213	237
SR308SI(SE)240	264
SR308SI(SE)249	273
SR308SI(SE)300	324
SR308SI(SE)322	346
SR308SI(SE)350	374

Nylon Type Part Numbers

Complete Set Assembled Chain Type	End Brackets Set
SR308SI(SE)...	AN308SKM

Complete Set Unassembled Chain Type	End Brackets Set
SR308SI(SE)...	AN308SK

Bright Zinc Plated Steel Type*

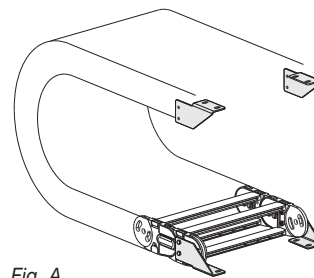
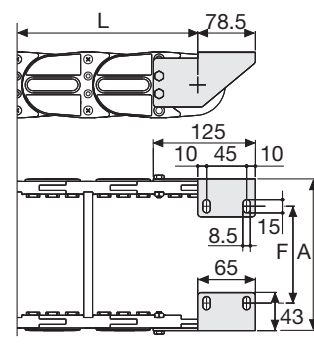

Fig. A
Chain fixed outside the radius. (Fig A)
See end brackets mounting variations page 31.



Chain Type	F mm
SR308SI(SE)038	20
SR308SI(SE)049	31
SR308SI(SE)063	45
SR308SI(SE)069	51
SR308SI(SE)083	65
SR308SI(SE)088	70
SR308SI(SE)095	77
SR308SI(SE)105	87
SR308SI(SE)113	95
SR308SI(SE)124	106
SR308SI(SE)138	120
SR308SI(SE)163	145
SR308SI(SE)188	170
SR308SI(SE)199	181
SR308SI(SE)213	195
SR308SI(SE)240	222
SR308SI(SE)249	231
SR308SI(SE)300	282
SR308SI(SE)322	304
SR308SI(SE)350	332

Bright Zinc Plated Steel Type Part Numbers

Complete Set Assembled Chain Type	End Brackets Set
SR308SI(SE)...	A308SKM □**

Complete Set Unassembled Chain Type	End Brackets Set
SR308SI(SE)...	A308SK □**

*Available on request in stainless steel
** 1=Pos.1; 2=Pos.2; 3=Pos.3
See end brackets mounting variations page 31.

Serie Heavy

SR308SI SR308SE

Nylon Cable Chain with openable frames

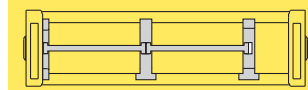

Separation System
To choose the separators see page. 154

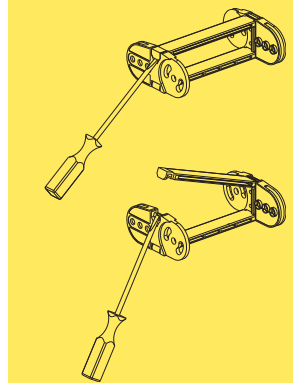

How to open the cover.

Protection version



On request available with aluminium covers

Inner radius openable

SR308CI □□□*□□□**

Outer radius openable

SR308CE□□□*□□□**

* Inner width (C)

** Bending radius (R)

For further information please consult Brevetti Stendalto's Technical Office