

SR309SI/SR309SE

Nylon Cable Chain with openable frames

Inner height (D) 75,5 mm

Strong double share Sideband & Frame construction with large anti-friction triple-pin. Frames openable from inner radius (..SI) and outer radius (..SE). As standard the chain comes with frames every second link, on request with frames every link. Vertical and horizontal modular separator system is available.

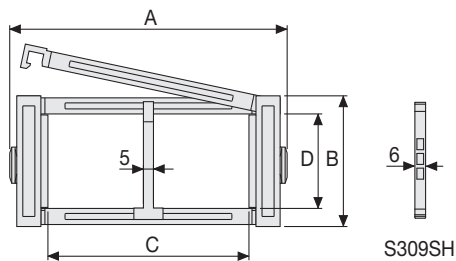

Separator

- Unassembled Part.no S309S
- Assembled Part.no S309SMC

Fastening separator

- Unassembled Part.no S309SH
- Assembled Part.no S309SHMC

Pin

Part.no PG309

Technical characteristics when self-supported

Speed	8 m/s
Acceleration	40 m/s ²

For higher requirements please consult our technical dept.

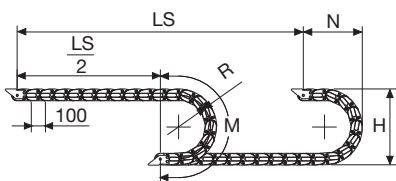

Length of chain (L)

Half travel distance ($\frac{LS}{2}$) plus length of curve (M)

$$L = \frac{LS}{2} + M$$

A	B	C	D	R	Weight/m	Chain
mm	mm	mm	mm	mm	kg	Part Number
120	100	64	75,5	200-250-300-350-400-500	4,03	SR309SI(SE)064□□□*
140	100	84	75,5	200-250-300-350-400-500	4,09	SR309SI(SE)084□□□*
165	100	109	75,5	200-250-300-350-400-500	4,17	SR309SI(SE)109□□□*
172	100	116	75,5	200-250-300-350-400-500	4,20	SR309SI(SE)116□□□*
195	100	139	75,5	200-250-300-350-400-500	4,27	SR309SI(SE)139□□□*
235	100	179	75,5	200-250-300-350-400-500	4,40	SR309SI(SE)179□□□*
270	100	214	75,5	200-250-300-350-400-500	4,51	SR309SI(SE)214□□□*
296	100	240	75,5	200-250-300-350-400-500	4,60	SR309SI(SE)240□□□*
320	100	264	75,5	200-250-300-350-400-500	4,67	SR309SI(SE)264□□□*
346	100	290	75,5	200-250-300-350-400-500	4,75	SR309SI(SE)290□□□*
370	100	314	75,5	200-250-300-350-400-500	4,83	SR309SI(SE)314□□□*
396	100	340	75,5	200-250-300-350-400-500	4,90	SR309SI(SE)340□□□*
420	100	364	75,5	200-250-300-350-400-500	4,99	SR309SI(SE)364□□□*

*Complete the code by inserting the value of the radius (R): Ex. SR309SI(SE)116 □ □ □
 Chain equipped with nylon frame every pitch: complete the code by inserting the letter D.
 Ex. SR309SI(SE)116250 □

R	H	N	M
mm	mm	mm	mm
200	500	350	830
250	600	400	985
300	700	455	1145
350	800	500	1300
400	900	555	1460
500	1100	650	1770

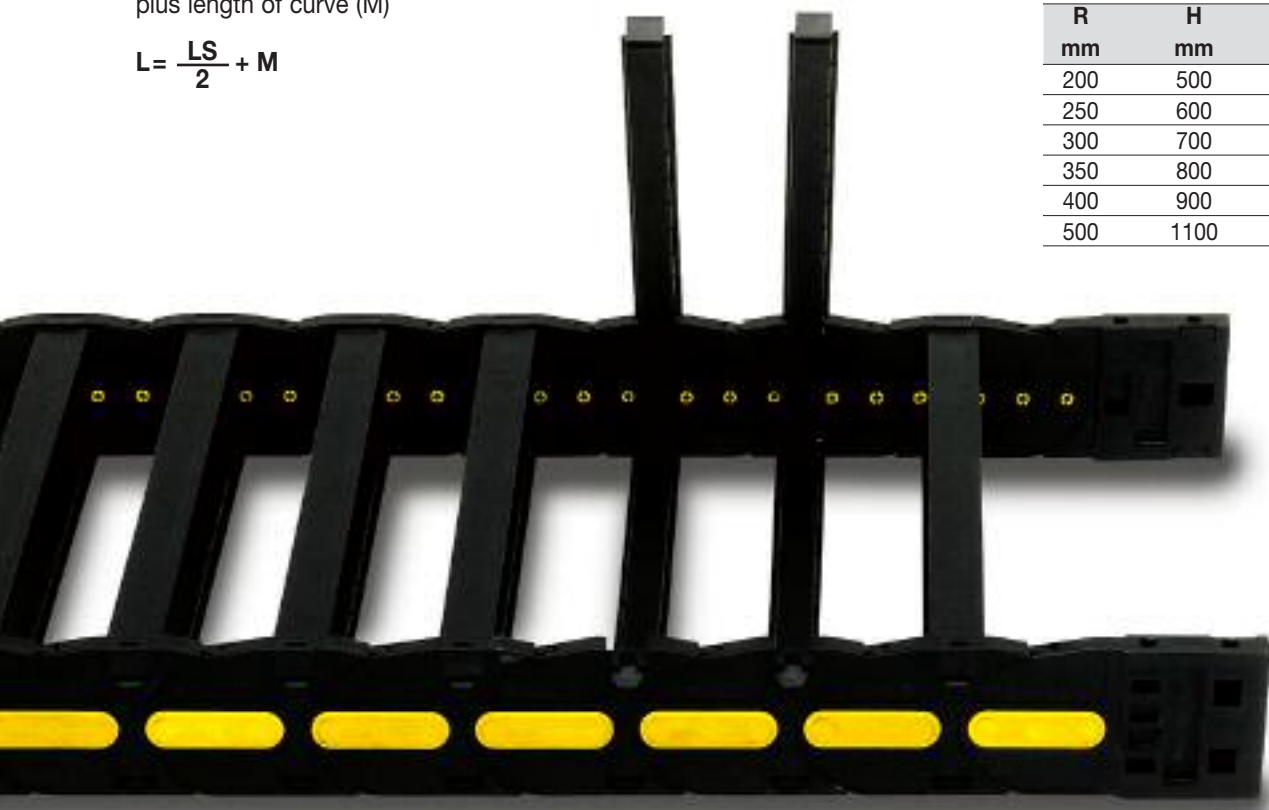

Version with frames mounted on every pitch.

Self-Supporting Capacity Diagram

The maximum length of the self-supporting capacity ($\frac{LS}{2}$) in relationship to the weight of the cables and hoses contained per linear metre.

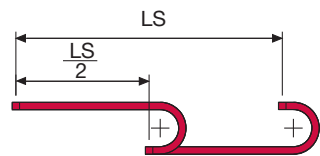
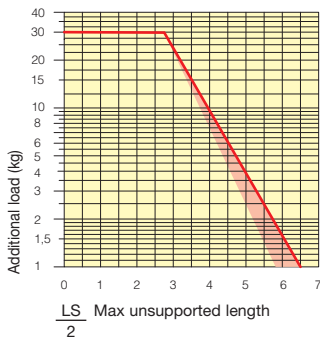

The red marking in the diagram area considers the difference of weight between various widths of chains assembled with nylon frames every second pitch.

For applications with $\frac{LS}{2}$ and weights not included in the area of the diagram showing self-supporting capacity, verify the possible use of support rollers (see page 30).

End Brackets

The end brackets set allows the two ends of the chain to be attached to the equipment.

Nylon Type

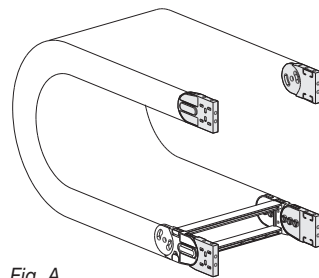

Fig. A
The chain can be fixed frontally, inner or outer radius. (Fig A)

Bright Zinc Plated Steel Type*

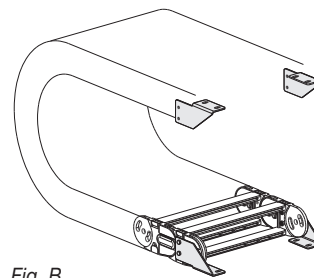
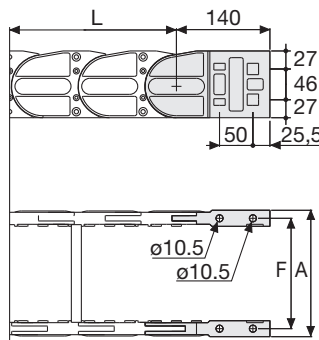

Fig. B
Chain fixed outside the radius. (Fig B)
See end brackets mounting variations page 31.



Chain Type	F mm
SR309SI(SE)064	92
SR309SI(SE)084	112
SR309SI(SE)109	137
SR309SI(SE)116	144
SR309SI(SE)139	167
SR309SI(SE)179	207
SR309SI(SE)214	242
SR309SI(SE)240	268
SR309SI(SE)264	292
SR309SI(SE)290	318
SR309SI(SE)314	342
SR309SI(SE)340	368
SR309SI(SE)364	392

Nylon Type Part Numbers

Complete Set Assembled	
Chain Type	End Brackets Set
SR309SI(SE)...	AN309KM

Complete Set Unassembled	
Chain Type	End Brackets Set
SR309SI(SE)...	AN309K

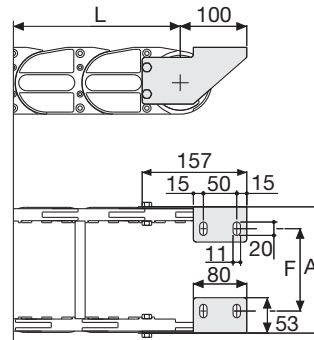

Chain Type	F mm
SR309SI(SE)064	50
SR309SI(SE)084	70
SR309SI(SE)109	95
SR309SI(SE)116	102
SR309SI(SE)139	125
SR309SI(SE)179	165
SR309SI(SE)214	200
SR309SI(SE)240	226
SR309SI(SE)264	250
SR309SI(SE)290	276
SR309SI(SE)314	300
SR309SI(SE)340	326
SR309SI(SE)364	350

Bright Zinc Plated Steel Type Part Numbers

Complete Set Assembled	
Chain Type	End Brackets Set
SR309SI(SE)...	A309SKM □**

Complete Set Unassembled	
Chain Type	End Brackets Set
SR309SI(SE)...	A309SK □**

*Available on request in stainless steel
** 1=Pos.1; 2=Pos.2; 3=Pos.3
See end brackets mounting variations page 31.

Serie Heavy

SR309SI SR309SE

Nylon Cable Chain
with openable frames

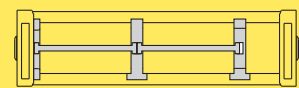

Separation System
To choose the separators see page. 154

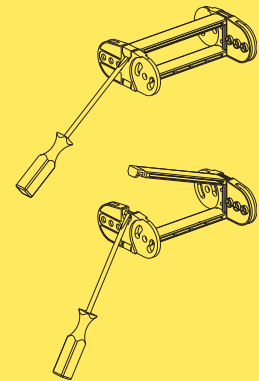

How to open the cover.

Protection version



On request available with aluminium covers

Inner radius openable
SR309CI □□□*□□□**

Outer radius openable
SR309CE □□□*□□□**

* Inner width (C)
** Bending radius (R)

For further information please consult Brevetti Stendalto's Technical Office