

Serie Medium

SR355A Nylon Cable Chain

Inner height (D) 31 mm

Construction by single link with antifriction pivot.

Cover removable from inner radius

Movable separators can be installed to create different compartments.

Part. no PG355

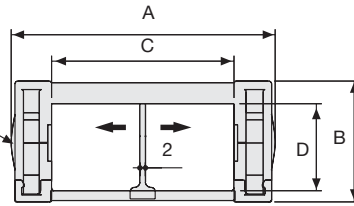

Separator

- Unassembled	Part. no S355
- Assembled	Part. no S355MC

Technical characteristics when self-supported

Speed	10 m/s
Acceleration	50 m/s ²

3

For higher requirements please consult our technical dept.



A	B	C	D	R	Weight/m	Chain
mm	mm	mm	mm	mm	kg	Part Number
74	43	45	31	75	1,40	SR355A045
74	43	45	31	100	1,40	SR355A046
74	43	45	31	150	1,40	SR355A047
74	43	45	31	200	1,40	SR355A048
94	43	65	31	75	1,50	SR355A065
94	43	65	31	100	1,50	SR355A066
94	43	65	31	150	1,50	SR355A067
94	43	65	31	200	1,50	SR355A068
124	43	95	31	75	1,70	SR355A095
124	43	95	31	100	1,70	SR355A096
124	43	95	31	150	1,70	SR355A097
124	43	95	31	200	1,70	SR355A098

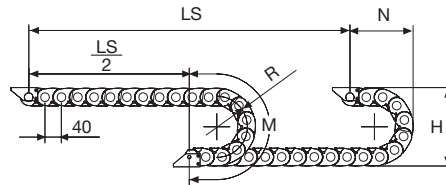

R	H	N	M
mm	mm	mm	mm
75	193	140	315
100	243	165	395
150	343	215	555
200	443	265	710

Length of chain (L)

Half travel distance ($\frac{LS}{2}$) plus length of curve (M)

$$L = \frac{LS}{2} + M$$

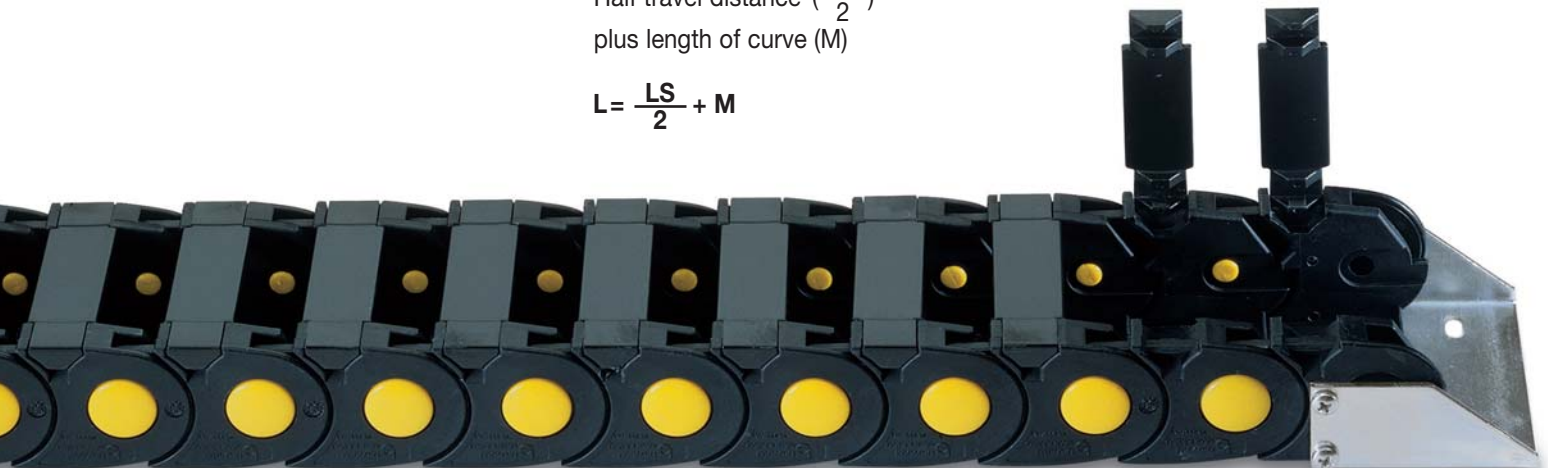

Self-Supporting Capacity Diagram

The maximum length of the self-supporting capacity ($\frac{LS}{2}$) in relationship to the weight of the cables and hoses contained per linear metre.

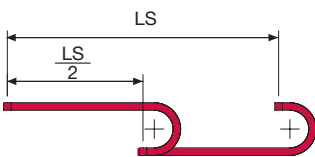
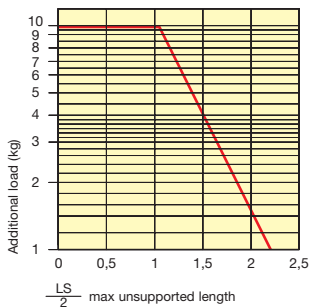

For applications with $\frac{LS}{2}$ and weights not included in the area of the diagram showing self-supporting capacity, verify the possible use of support rollers (see page 30).

End Brackets

The end brackets set allows the two ends of the chain to be attached to the equipment.

Nylon Type

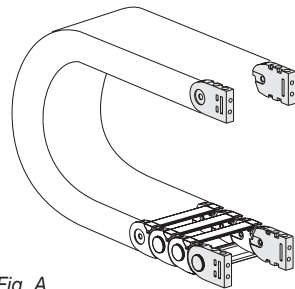

Fig. A

End brackets can be mounted in any position. (Fig. A)
See end brackets mounting variations: page 31.

Bright Zinc Plated Steel Type*

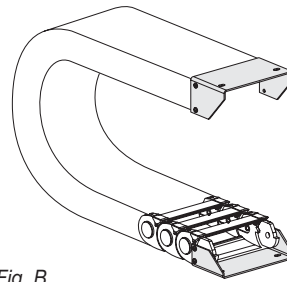
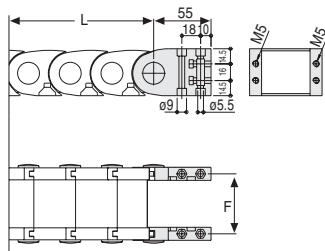
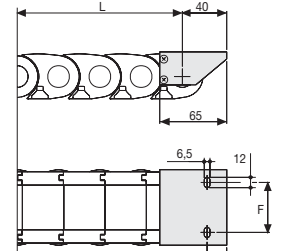

Fig. B

End brackets can be mounted in any position. (Fig. B)
See end brackets mounting variations: page 31.



Chain	F
	mm
SR355A C=45	59
SR355A C=65	79
SR355A C=95	109



Chain	F
	mm
SR355A C=45	50
SR355A C=65	70
SR355A C=95	100

Nylon Type Part Numbers

Complete Set Assembled

Chain Type	End Brackets Set
SR355A C=45	AN355KM
SR355A C=65	AN355KM
SR355A C=95	AN355KM

Complete Set Unassembled

Chain Type	End Brackets Set
SR355A C=45	AN355K
SR355A C=65	AN355K
SR355A C=95	AN355K

Bright Zinc Plated Steel Type Part Numbers

Complete Set Assembled

Chain Type	End Brackets Set
SR355A C=45	AP355AKM1
SR355A C=65	AM355AKM1
SR355A C=95	AG355AKM1

Complete Set Unassembled

Chain Type	End Brackets Set
SR355A C=45	AP355AK1
SR355A C=65	AM355AK1
SR355A C=95	AG355AK1

* Available on request in stainless steel.

Serie Medium

SR355A

Nylon Cable Chain

3

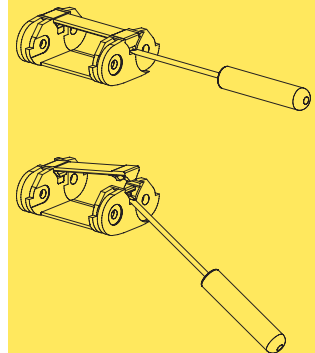

How to open the cover.

Special tool to remove the connecting pivots: part number PZ010.

For further information please consult Brevetti Stendalto's Technical Office